



SaniServ[®]
An AFFINIS GROUP Company

Item No. _____
Quantity _____
Job Name _____

Designed For Low Volume Applications
Two 3 oz. Servings per minute – 6 Qt. Capacity
Economical in Price & Space!

Model DF200
Countertop
**Soft Serve Ice Cream /
Yogurt Machine**

The **SaniServ** model DF200 Soft Serve/Yogurt Machine is ideal for providing small servings, samplers, and adding a-la-mode to favorite desserts. Economical in price and space, **DuraFreeze** offers the prospect for high profits and customer satisfaction.

Space Saving

Smallest Footprint Design – **SaniServ DuraFreeze 200** saves valuable floor space and turns the countertop into a real profit center by serving high profit ice cream and yogurt products.

Easy Cleaning and Operation

Fewer Parts = Simplified Cleaning – **SaniServ** equipment is designed and built with the fewer parts to be disassembled, cleaned and sanitized than any other machine in the industry.

High Return on Investment

Increased Profits – **SaniServ** machines combine affordable efficiency with consistent product quality and fast quiet operation to insure customer satisfaction with high profit frozen beverages.

Quality Design

Durability – **SaniServ** machines are built to achieve long and dependable life through simplicity of design. Every machine is shipped standard with a stainless steel exterior, durable construction, heavy-duty components and consistency systems.



Pending



Made in the USA

SaniServ Model DF200

Countertop Soft Serve Ice Cream / Yogurt Machine

For sales information contact:

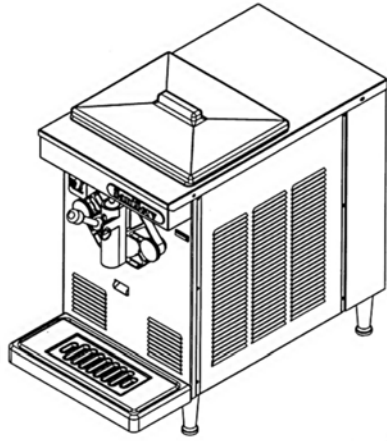

Minimum Wall Clearance
Both Sides and Back -
6 inches (152 mm)

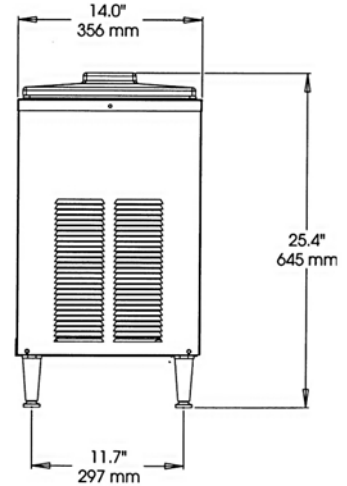
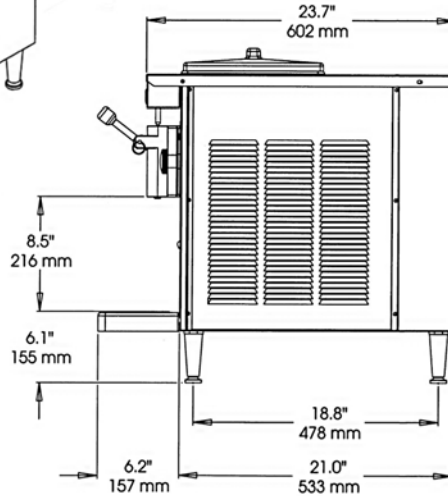

ELECTRICAL				WIDTH INCHES (mm)	HEIGHT INCHES (mm)	DEPTH INCHES (mm)	WEIGHT LBS. (Kg)	VOLUME CU FT. (cu. m.)
VOLTS	Hz	Ph.	Amps					
115	60	1	11	14 (356)	25.4 (645)	23.7 (602)	145 (66)	8.6 (.25)
Shipping Specifications				22.5 (571)	31.5 (800)	34.5 (876)	172 (78)	

Specifications:

Cooling System: Air Only

Dasher and Compressor Motors:
1/4 HP Dasher 1/3 HP Compressor

Refrigerant Type: R404A

Listings: NSF
Pending UL

Features:

Evaporator and Mix Reservoir
Capacity: 6 Quarts (5.7 liters)

Dasher: Heavy-Duty Stainless Steel with low friction scraper blades.

Controls: Automatic consistency controls.

Warranty:

Parts	90 days
Compressor	1 year
Labor	30 days

Options:

Tune Up Kit
Machine Stand
Custom Graphic

We reserve the right to change specifications and product design without notice. Such revisions do not entitle the buyer to corresponding changes, improvements, additions or replacements for previously purchased equipment.

ZAMA

WWW.ZAMA-ENETRPRISE.COM
1-866-425-5669 Fax: 1-305-670-0044
Miami, FL 33156



Made in the USA

Rev. 2/06