



**SaniServ**<sup>®</sup>  
An AFFINIS GROUP Company

Item No. \_\_\_\_\_  
Quantity \_\_\_\_\_  
Job Name \_\_\_\_\_

*Designed For High Volume Applications*  
20 Gallons per Hour – 20 Quart Capacity  
**High production in a Traditional Floor Model Design!!**

**Model 714**  
Floor Model  
**Frozen Beverage Machine**

The **SaniServ** Model 714 Floor Model Frozen Beverage Machine provides high production frozen beverages even in the busiest of applications! With its sleek single barrel profile and traditional floor model design, the 714 has the ability to offer many types of slush beverages. Choose from frozen margaritas and daiquiris to frozen fruit flavor drinks such as frozen lemonade and fruit smoothies!

**Space Saving**

*Compact Floor Model Design* – **SaniServ** model 714 provides a high volume dispenser in a compact, traditional floor model design. Operators will enjoy the ease of operation and the ability to utilize the 714's versatility to provide the different types of frozen beverages that customers want!

**Easy Cleaning and Operation**

*Fewer Parts = Simplified Cleaning* – **SaniServ** equipment is designed and built with the fewer parts to be disassembled, cleaned and sanitized than any other machine in the industry.

**High Return on Investment**

*Increased Profits* – **SaniServ** machines combine affordable efficiency with consistent product quality and fast quiet operation to insure customer satisfaction with high profit frozen beverages.

**Quality Design**

*Durability* – **SaniServ** machines are built to achieve long and dependable life through simplicity of design. Every machine is shipped standard with a stainless steel exterior, durable steel interior frame construction, heavy-duty components and consistency systems.



Made in the USA

# SaniServ Model 714

## Floor Model Frozen Beverage/Cocktail Freezer

For sales information contact:

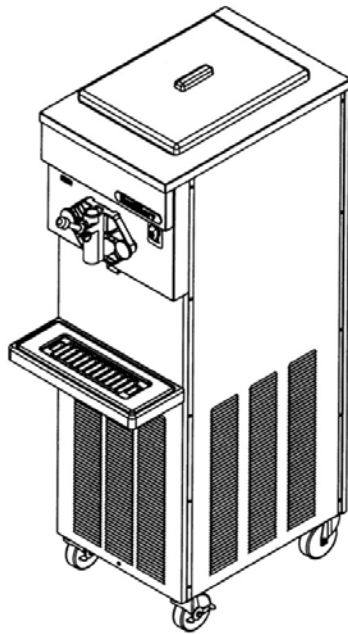

Minimum Wall Clearance  
Both Sides and Back -  
6 inches (152 mm)

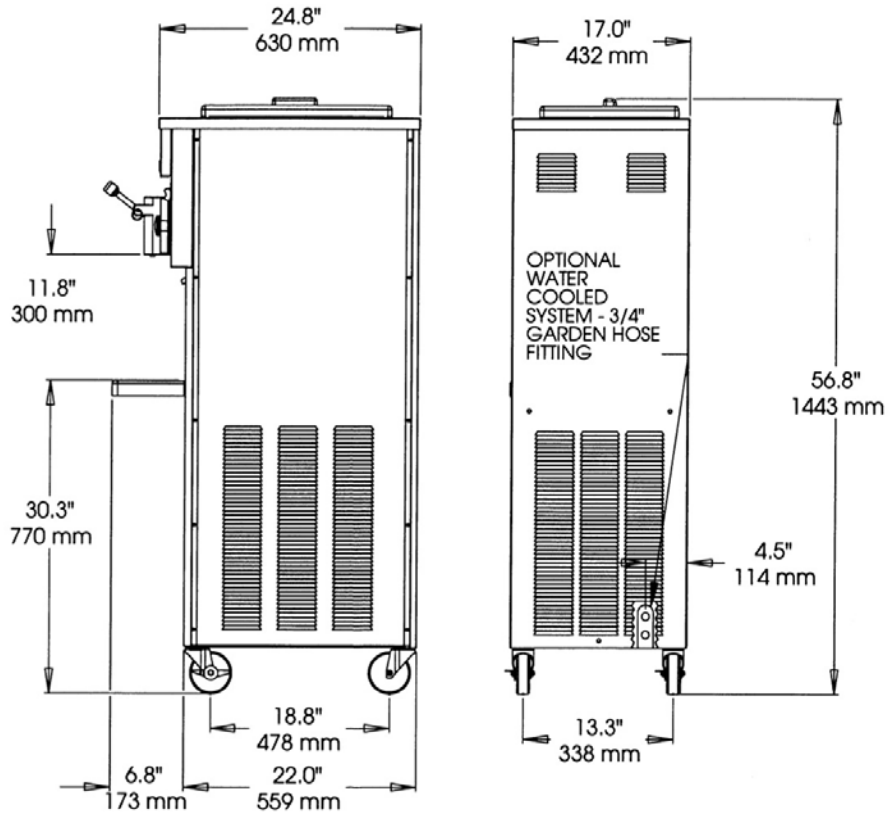

ELECTRICAL				WIDTH	HEIGHT	DEPTH	WEIGHT	VOLUME
VOLTS	Hz	Ph.	Amps	INCHES (mm)	INCHES (mm)	INCHES (mm)	LBS. (Kg)	CU FT. (cu. m.)
208-230	60	1	15	17 (432)	56.8 (1443)	24.8 (630)	305 (139)	
Shipping Specifications				24.5 (622)	58.1 (1476)	40.5 (1029)	345 (157)	32.4 (.91)

### Specifications:

**Cooling System:** Air or Water

**Dasher and Compressor Motors:**  
1/2 HP Dasher    2 HP Compressor

**Refrigerant Type:** R404A

**Listings:** UL, cUL, NSF

### Features:

**Evaporator and Mix Reservoir Capacity:** 20 Quarts (18.9 liters)

**Dasher:** Heavy-Duty Stainless Steel with low friction scraper blades.

**Controls:** Automatic consistency controls for improved product consistency.

**Solid-state Automatic Visual Mix Out Alert System**

### Warranty:

Parts	1 year
Compressor	5 years
Evaporator	5 years

### Options:

- Tune Up Kit
- Parts Tray
- Drink Spinner
- Syrup Rail
- Wash Out Kit - 3/8" Flare Fitting
- Water Cooled - 3/4" Garden Hose Fitting
- Export Voltage

We reserve the right to change specifications and product design without notice. Such revisions do not entitle the buyer to corresponding changes, improvements, additions or replacements for previously purchased equipment.

# ZAMA

WWW.ZAMA-ENETRPRRISE.COM  
1-866-425-5669 Fax: 1-305-670-0044  
Miami, FL 33156



Made in the USA

Rev. 2/06