



SaniServ[®]
An AFFINIS GROUP Company

Item No. _____
Quantity _____
Job Name _____

Highest Production and Capacity Requirements
28 Gallons per Hour – 35 Quart Capacity
A Frozen Beverage Industry Leader!

Model 704
Counter Model
Frozen Beverage Machine

The **SaniServ** Model 704 Frozen Beverage Machine is perfect for providing a high volume of frozen drinks for the busiest applications and operating hours! The 704 has the highest production capability in the frozen beverage industry! With its quick product freezing and recovery time, along with heavy-duty design, large capacity freezing barrel and product reservoir, the 704 can provide perfect frozen drinks every time!

Space Saving

Small Footprint Design - **SaniServ** model 704 provides super high production while saving valuable floor space by utilizing the countertop design. With the 704, there is no need to purchase a floor model type machine to attain high production capacity and capability.

Easy Cleaning and Operation

Fewer Parts = Simplified Cleaning – **SaniServ** equipment is designed and built with the fewer parts to be disassembled, cleaned and sanitized than any other machine in the industry.

High Return on Investment

Increased Profits – **SaniServ** machines combine affordable efficiency with consistent product quality and fast quiet operation to insure customer satisfaction with high profit frozen beverages.

Quality Design

Durability – **SaniServ** machines are built to achieve long and dependable life through simplicity of design. Every machine is shipped standard with a stainless steel exterior, durable steel interior frame construction, heavy-duty components and consistency systems.



Shown with optional legs.



Made in the USA

SaniServ Model 704

Counter Model Frozen Beverage/Cocktail Freezer

For sales information contact:

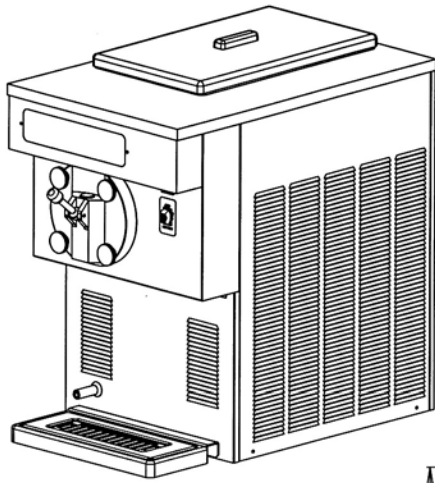

Minimum Wall Clearance
Both Sides and Back -
6 inches (152 mm)

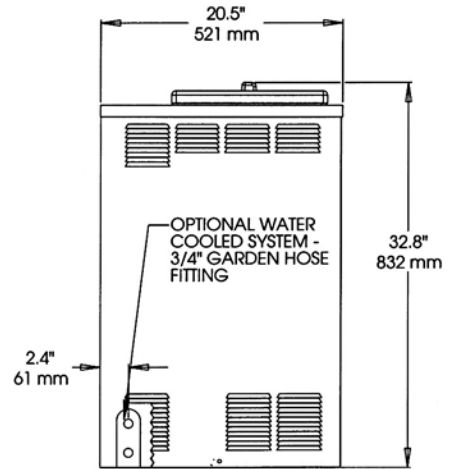
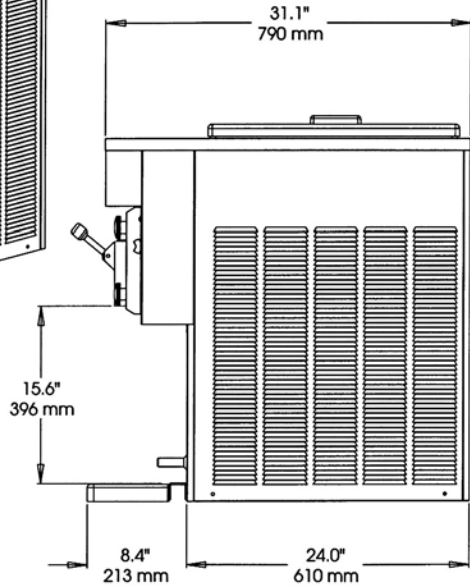

ELECTRICAL				WIDTH	HEIGHT	DEPTH	WEIGHT	VOLUME
VOLTS	Hz	Ph.	Amps	INCHES (mm)	INCHES (mm)	INCHES (mm)	LBS. (Kg)	CU FT. (cu. m.)
208-230	60	1	25	20.5 (521)	32.8 (832)	31.1 (790)	310 (141)	
208-230	60	3	20					
Shipping Specifications				31.3 (794)	40.5 (1029)	40.5 (1029)	350 (159)	18 (.51)

Specifications:

Cooling System: Air or Water
Dasher and Compressor Motors:
1/2 HP Dasher 2 HP Compressor
Refrigerant Type: R404A
Listings: UL, cUL, NSF

Features:

Evaporator and Mix Reservoir Capacity: 35 Quarts (33 liters)
Dasher: Heavy-Duty Stainless Steel with low friction scraper blades.
Controls: Automatic consistency controls for improved product consistency.
Solid-state Automatic Audio and Visual Mix Out Alert System
Includes Counter Top Mounting Pad

Warranty:

Parts 1 year
Compressor 5 years
Evaporator 5 years

Options:

Tune Up Kit Parts Tray
Auto-fill Lid Drink Spinner
Machine Stand Counter Legs
Water Cooled - 3/4" Garden Hose Fitting
Export Voltage
Remote Condenser*

* Requires a remote condensing unit (condenser & compressor) connected by two refrigeration lines.

We reserve the right to change specifications and product design without notice. Such revisions do not entitle the buyer to corresponding changes, improvements, additions or replacements for previously purchased equipment.