



**SaniServ**<sup>®</sup>  
An AFFINIS GROUP Company

Item No. \_\_\_\_\_  
Quantity \_\_\_\_\_  
Job Name \_\_\_\_\_

*Designed For Higher Volume Applications*  
Seven – 4 oz. Servings per Minute – 20 Qt. Capacity  
*Great for Restaurants, Buffets, & Ice Cream Shops*

**Model 614**  
**Floor Model**  
**Shake Machine**

The **SaniServ** Model 614 Shake Dispenser provides high profit, consistent quality shakes in a traditional single barrel flavor design! The 614 ease of operation is a favorite among owners and operators. The high production, capacity and recovery time insures the 614 is a perfect piece of equipment for satisfying customer demand. By adding a drink spinner and syrup rail, the 614 is sure to provide everyone's favorite shake flavor!

### Space Saving

*Compact Floor Model Design* - **SaniServ** provides a high volume of milk shake in the traditional floor model design. Operators can turn that valuable floor space into a high profit center by providing consistent high quality shakes customers demand.

### Easy Cleaning and Operation

*Fewer Parts = Simplified Cleaning* – **SaniServ** equipment is designed and built with the fewer parts to be disassembled, cleaned and sanitized than any other machine in the industry.

### High Return on Investment

*Increased Profits* – **SaniServ** machines combine efficiency with consistent product quality and fast quiet operation while insuring customer satisfaction with high profit ice cream or yogurt products.

### Quality Design

*Durability* – **SaniServ** machines are built to achieve long and dependable life through simplicity of design. Every machine is shipped standard with a stainless steel exterior, durable steel interior frame construction, heavy-duty components and consistency systems.



Made in the USA

# SaniServ Model 614

## Floor Model Shake Freezer

For sales information contact:

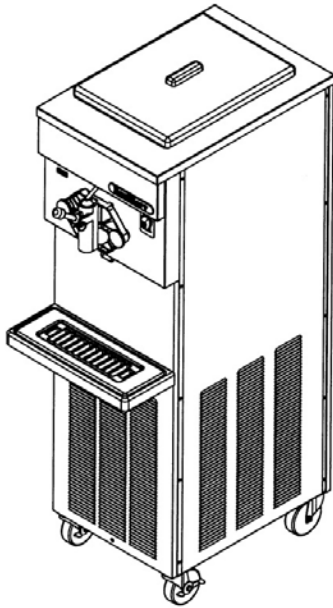

Minimum Wall Clearance  
Both Sides and Back -  
6 inches (152 mm)

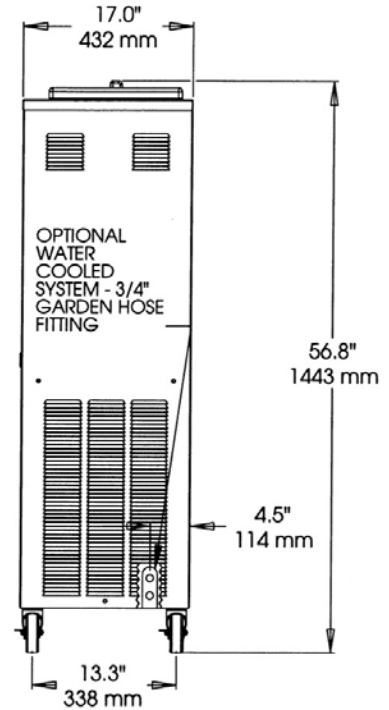
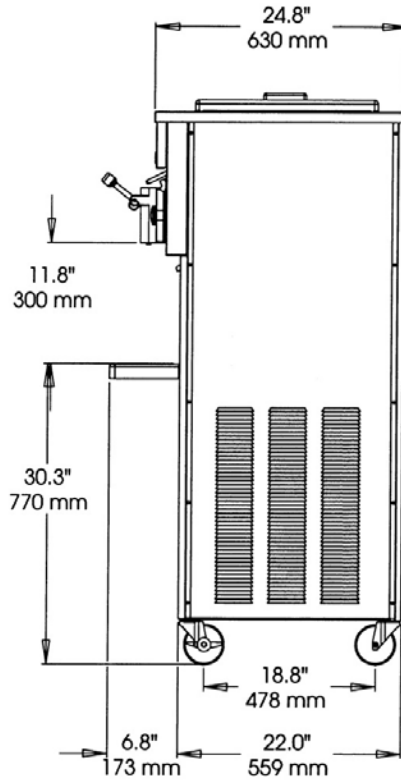

ELECTRICAL				WIDTH	HEIGHT	DEPTH	WEIGHT	VOLUME
VOLTS	Hz	Ph.	Amps	INCHES (mm)	INCHES (mm)	INCHES (mm)	LBS. (Kg)	CU FT. (cu. m.)
208-230	60	1	20	17 (432)	56.8 (1443)	24.8 (630)	338 (153)	
208-230	60	3	20					
Shipping Specifications				24.5 (622)	58.1 (1476)	34.5 (876)	380 (172)	32.4 (.92)

### Specifications:

**Cooling System:** Air or Water

**Dasher and Compressor Motors:**  
1/2 HP Dasher    2 HP Compressor

**Refrigerant Type:** R404A

**Listings:** UL, cUL, NSF

### Features:

**Evaporator and Mix Reservoir Capacity:** 20 Quarts (18.9 liters)

**Dasher:** Heavy-Duty Stainless Steel with low friction scraper blades.

**Controls:** Automatic consistency controls for improved consistency.

**Tamper Proof Automatic Visual Mix Out System**

### Warranty:

Parts	1 year
Compressor	5 years
Evaporator	5 years

### Options:

- Tune Up Kit
- Parts Tray
- Syrup Rail
- Drink Spinner
- Water Cooled - 3/4" Garden Hose Fitting
- Wash Out Kit - 3/8" Flare Fitting

We reserve the right to change specifications and product design without notice. Such revisions do not entitle the buyer to corresponding changes, improvements, additions or replacements for previously purchased equipment.



WWW.ZAMA-ENETRPRISE.COM  
1-866-425-5669 Fax: 1-305-670-0044  
Miami, FL 33156



Made in the USA