



SaniServ[®]
An AFFINIS GROUP Company

Item No. _____
Quantity _____
Job Name _____

Designed For Medium Volume Applications

Two - 12 oz. Shakes per Minute - 20 Qt. Capacity

Great for Restaurants and Bars

Model 608

Countertop

Shake Machine

with **AccuFreeze Control**

The **SaniServ** Model 608 Shake Machine provides smooth quality, high profit shakes anytime, anywhere! Owners and operators can easily add high profit shakes to any menu and provide quality drinks everybody loves! By adding an optional Drink Spinner and a Syrup Rail for flavors, customers can also enjoy a wide flavor offering of quality shake products that keep them coming back for more of their own personal favorites! Also available in a Smoothie version.

Space Saving

Small Footprint Design - **SaniServ** model 608 saves valuable floor space and turns the countertop into a real profit center by serving a large volume of high profit shake beverages.

Easy Cleaning and Operation

Fewer Parts = Simplified Cleaning - **SaniServ** equipment is designed and built with the fewer parts to be disassembled, cleaned and sanitized than any other machine in the industry.

High Return on Investment

Increased Profits - **SaniServ** machines combine efficiency with consistent product quality and fast quiet operation while insuring customer satisfaction with high profit ice cream or yogurt products.

Quality Design

Durability - **SaniServ** machines are built to achieve long and dependable life through simplicity of design. Every machine is shipped standard with a stainless steel exterior, durable steel interior frame construction, heavy-duty components and consistency systems.



Made in the USA

SaniServ Model 608

Counter Model Shake Freezer

For sales information contact:

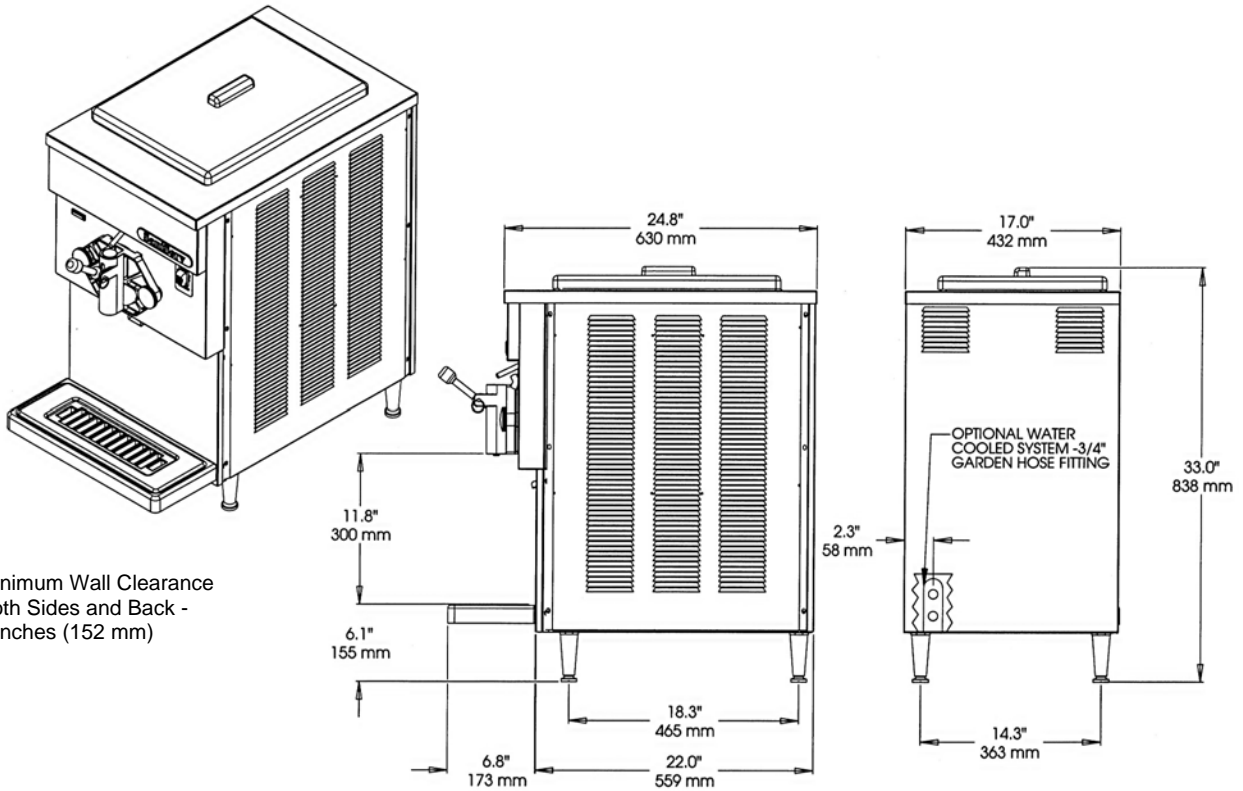

Minimum Wall Clearance
Both Sides and Back -
6 inches (152 mm)

ELECTRICAL				WIDTH	HEIGHT	DEPTH	WEIGHT	VOLUME
VOLTS	Hz	Ph.	Amps	INCHES (mm)	INCHES (mm)	INCHES (mm)	LBS. (Kg)	CU FT. (cu. m.)
115	60	1	11	17 (432)	33 (838)	24.8 (630)	208 (95)	
Shipping Specifications				22.5 (572)	40.5 (1029)	34.5 (876)	238 (108)	14.8 (.42)

Specifications:

Cooling System: Air or Water

Dasher and Compressor Motors:
1/4 HP Dasher 3/4 HP Compressor

Refrigerant Type: R404A

Listings: UL, cUL, NSF

Features:

Evaporator and Mix Reservoir Capacity: 20 Quarts (18.9 liters)

Dasher: Heavy-Duty Stainless Steel with low friction scraper blades.

Controls: *AccuFreeze* solid-state control for accurate product consistency.

Tamper Proof Automatic Visual Mix Out System

Warranty:

Parts	1 year
Compressor	5 years
Evaporator	5 years

Options:

- Tune Up Kit
- Parts Tray
- Syrup Rail
- Counter Top Mounting Pad
- Machine Stand
- Water Cooled - 3/4" Garden Hose Fitting
- Wash Out Kit - 3/8" Flare Fitting
- Export Voltages
- Smoothie** Version

We reserve the right to change specifications and product design without notice. Such revisions do not entitle the buyer to corresponding changes, improvements, additions or replacements for previously purchased equipment.

ZAMA

WWW.ZAMA-ENETRPRIZE.COM
1-866-425-5669 Fax: 1-305-670-0044
Miami, FL 33156



Made in the USA

Rev. 2/06