



SaniServ®

An AFFINIS GROUP Company

Item No. _____
Quantity _____
Job Name _____

Designed For Higher Volume Applications
Three – 12 oz. Shakes per Minute – 20 Qt. Capacity
Great for Quick Service Restaurants and Drive-Thrus

Model 601
Countertop
Shake Machine

The **SaniServ** Model 601 Shake Machine provides a high volume of smooth quality shakes! With its increased production and recovery time, owners and operators can always provide plenty of high profit shake product even during peak operating periods. As always, adding an optional Drink Spinner and Syrup Rail for flavors can create customer favorites. The 601 provides customer satisfaction every time by insuring their favorite shakes are always available!

Space Saving

Small Footprint Design - **SaniServ** model 601 saves valuable floor space and turns the countertop into a real profit center by serving a large volume of high profit shake beverages.

Easy Cleaning and Operation

Fewer Parts = Simplified Cleaning – **SaniServ** equipment is designed and built with the fewer parts to be disassembled, cleaned and sanitized than any other machine in the industry.

High Return on Investment

Increased Profits – **SaniServ** machines combine efficiency with consistent product quality and fast quiet operation while insuring customer satisfaction with high profit ice cream or yogurt products.

Quality Design

Durability – **SaniServ** machines are built to achieve long and dependable life through simplicity of design. Every machine is shipped standard with a stainless steel exterior, durable steel interior frame construction, heavy-duty components and consistency systems.



Made in the USA

SaniServ Model 601

Counter Model Shake Freezer

For sales information contact:

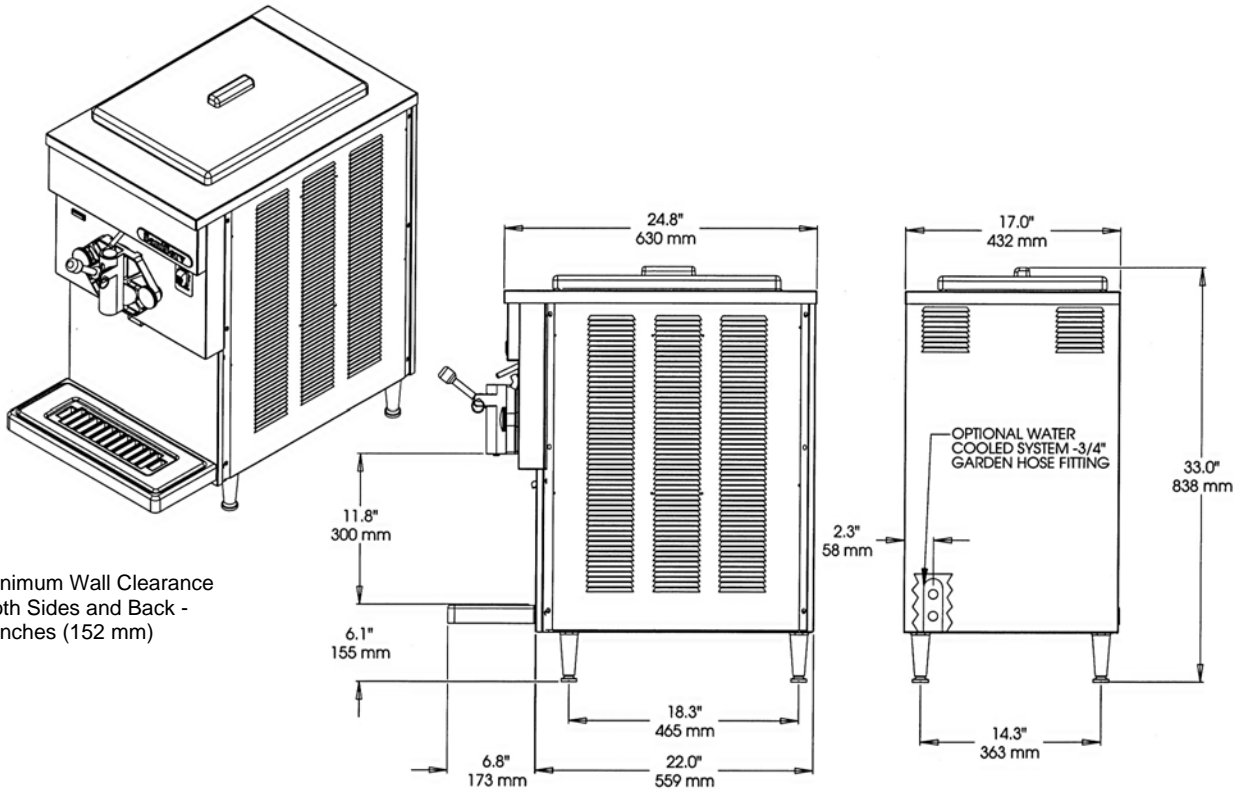

Minimum Wall Clearance
Both Sides and Back -
6 inches (152 mm)

ELECTRICAL				WIDTH INCHES (mm)	HEIGHT INCHES (mm)	DEPTH INCHES (mm)	WEIGHT LBS. (Kg)	VOLUME CU FT. (cu. m.)
VOLTS	Hz	Ph.	Amps					
208-230	60	1	20	17 (432)	33 (838)	24.8 (630)	242 (110)	
208-230	60	3	15					
Shipping Specifications				22.5 (572)	36 (914)	34.5 (876)	269 (122)	14.8 (.42)

Specifications:

Cooling System: Air or Water

Dasher and Compressor Motors:
1/2 HP Dasher 1 HP Compressor

Refrigerant Type: R404A

Listings: UL, cUL, NSF

Features:

Evaporator and Mix Reservoir Capacity: 20 Quarts (18.9 liters)

Dasher: Heavy-Duty Stainless Steel with low friction scraper blades.

Controls: Automatic consistency controls for improved consistency.

Tamper Proof Automatic Visual Mix Out System

Warranty:

Parts	1 year
Compressor	5 years
Evaporator	5 years

Options:

- Tune Up Kit
- Parts Tray
- Syrup Rail
- Counter Top Mounting Pad Machine Stand
- Water Cooled - 3/4" Garden Hose Fitting
- Wash Out Kit - 3/8" Flare Fitting
- Export Voltages

We reserve the right to change specifications and product design without notice. Such revisions do not entitle the buyer to corresponding changes, improvements, additions or replacements for previously purchased equipment.