



SaniServ[®]
An AFFINIS GROUP Company

Item No. _____
Quantity _____
Job Name _____

Designed For Higher Volume Applications

Seven - 4 oz. Servings per Minute per side

and 20 Quart Capacity per side

Ideal for Self-serv Buffets, Cafeterias, Quick Service Restaurants

Model 522

Floor Model

Twist Soft Serve Ice Cream /

Yogurt Machine

The **SaniServ** Model 522 Soft Serve and Frozen Yogurt Machine provides the highest volume of two individual flavors as well as a flavor twist. The 522 offers the highest volume of high profit, consistent quality soft serve and yogurt products in the SaniServ product lineup. Two large independent flavor product reservoirs and barrels guarantee separation of product and flavors. Always easy to operate, large product capacity and quick recovery time insure customers receive their favorite flavors individually or with a twist!

Space Maximizing

Traditional Floor Model Design - **SaniServ** model 522 turns valuable floor space into a real profit center by serving the highest volume of two high profit ice cream and yogurt product flavors along with the ability to twist the flavors into a frozen favorite.

Easy Cleaning and Operation

Fewer Parts = Simplified Cleaning - **SaniServ** equipment is designed and built with the fewer parts to be disassembled, cleaned and sanitized than any other machine in the industry.

High Return on Investment

Increased Profits - **SaniServ** machines combine efficiency with consistent product quality and fast quiet operation while insuring customer satisfaction with high profit ice cream or yogurt products.

Quality Design

Durability - **SaniServ** machines are built to achieve long and dependable life through simplicity of design. Every machine is shipped standard with a stainless steel exterior, durable steel interior frame construction, heavy-duty components and consistency systems.



Made in the USA

SaniServ Model 522

Floor Model Twist Softserv / Yogurt Freezer

For sales information contact:

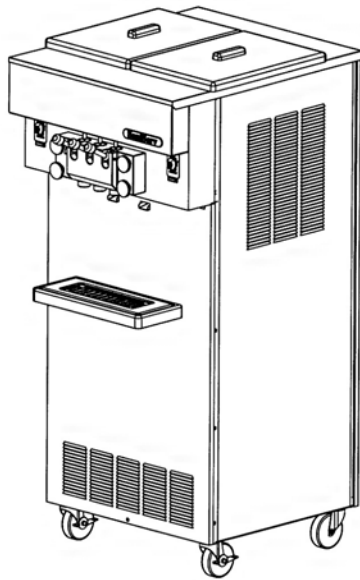

Minimum Wall Clearance
Both Sides and Back -
6 inches (152 mm)

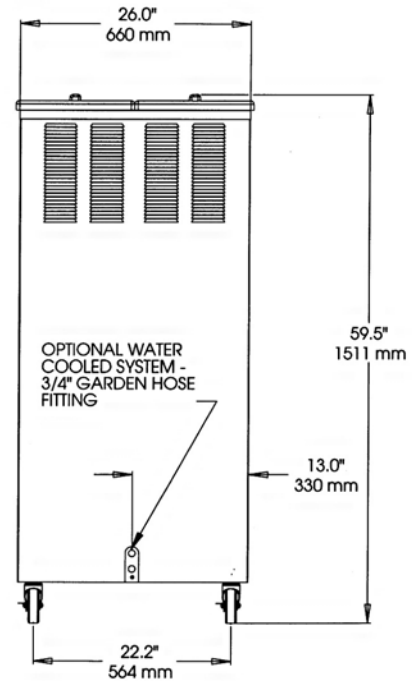
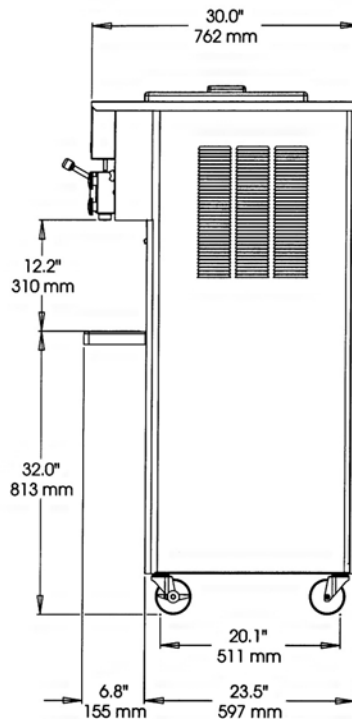

ELECTRICAL				WIDTH INCHES (mm)	HEIGHT INCHES (mm)	DEPTH INCHES (mm)	WEIGHT LBS. (Kg)	VOLUME CU FT. (cu. m.)
VOLTS	Hz	Ph.	Amps					
208-230	60	1	30*	26 (660)	59.5 (1511)	30 (762)	603 (274)	
208-230	60	3	20*					
Shipping Specifications				36 (914)	65 (1650)	40 (1016)	634 (288)	54.8 (1.53)

* Two separate circuits required.

Specifications:

Cooling System: Air or Water

Dasher and Compressor Motors:
(2) 1 HP Dashers (2) 2 HP Compressors

Refrigerant Type: R404A

Listings: UL, cUL, NSF

Features:

Evaporator and Mix Reservoir
Capacity: 11Quarts (10.4 liters) **per side**

Dasher: Heavy-Duty Stainless Steel with low friction scraper blades.

Controls: Automatic consistency controls for improved consistency.

Solid State Automatic Audio and Visual Mix Out System

Warranty:

Parts	1 year
Compressor	5 years
Evaporator	5 years

Options:

- Tune Up Kit
- Parts Tray
- Syrup Rail
- Water Cooled - 3/4" Garden Hose Fitting
- Wash Out Kit - 3/8" Flare Fitting
- Export Voltage

We reserve the right to change specifications and product design without notice. Such revisions do not entitle the buyer to corresponding changes, improvements, additions or replacements for previously purchased equipment.

ZAMA

WWW.ZAMA-ENETRPRISE.COM
1-866-425-5669 Fax: 1-305-670-0044
Miami, FL 33156



Made in the USA

Rev. 2/06