



SaniServ®

An AFFINIS GROUP Company

Item No. _____
Quantity _____
Job Name _____

Designed For Higher Volume Applications
Seven – 4 oz. Servings per Minute – 20 Qt. Capacity
Great for Restaurants, Buffets, & Ice Cream Shops

Model 414

Floor Model
**Soft Serve Ice Cream /
Yogurt Machine**

The **SaniServ** Model 414 Soft Serve and Frozen Yogurt Machine provides high profit, consistent quality soft serve and yogurt products in a traditional single barrel design! The ease of operation of the model 414 is a favorite among owners and operators. The high production, capacity and recovery time insures the 414 is a perfect piece of equipment for satisfying customer demand and providing the frozen treats they want at any time!

Space Saving

Compact Floor Model Design - **SaniServ** model 414 provides a high volume of soft serve and frozen yogurt products in the traditional floor model design. Operators can turn that valuable floor space into a high profit center by providing frozen treats customers enjoy!

Easy Cleaning and Operation

Fewer Parts = Simplified Cleaning – **SaniServ** equipment is designed and built with the fewer parts to be disassembled, cleaned and sanitized than any other machine in the industry.

High Return on Investment

Increased Profits – **SaniServ** machines combine efficiency with consistent product quality and fast quiet operation while insuring customer satisfaction with high profit ice cream or yogurt products.

Quality Design

Durability – **SaniServ** machines are built to achieve long and dependable life through simplicity of design. Every machine is shipped standard with a stainless steel exterior, durable steel interior frame construction, heavy-duty components and consistency systems.



Made in the USA

SaniServ Model 414

Floor Model Shake Freezer

For sales information contact:

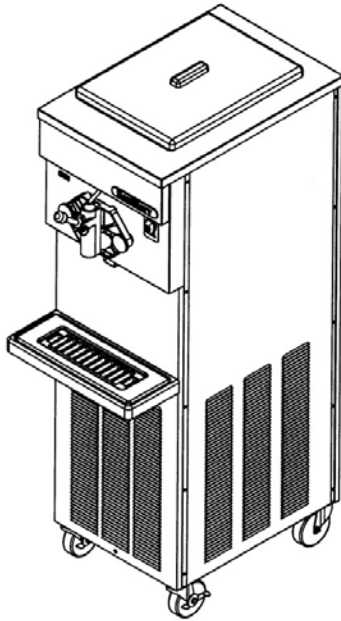

Minimum Wall Clearance
Both Sides and Back -
6 inches (152 mm)

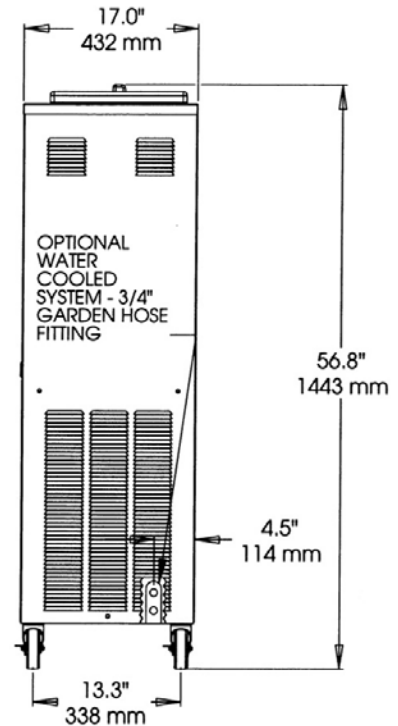
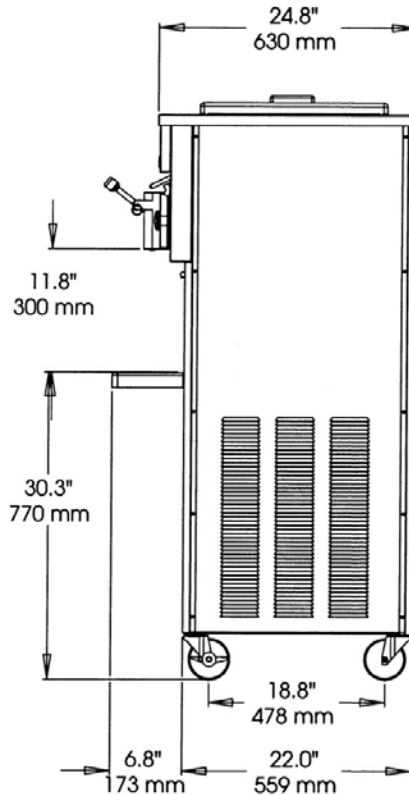

ELECTRICAL				WIDTH INCHES (mm)	HEIGHT INCHES (mm)	DEPTH INCHES (mm)	WEIGHT LBS. (Kg)	VOLUME CU FT. (cu. m.)
VOLTS	Hz	Ph.	Amps					
208-230	60	1	25	17 (432)	56.5 (1435)	24.8 (726)	338 (153)	
208-230	60	3	20					
Shipping Specifications				24.5 (622)	58.1 (1476)	40.5 (1029)	380 (172)	32.4 (.92)

Specifications:

Cooling System: Air or Water

Dasher and Compressor Motors:
1 HP Dasher 2 HP Compressor

Refrigerant Type: R404A

Listings: UL, cUL, NSF

Features:

Evaporator and Mix Reservoir Capacity: 20 Quarts (18.9 liters)

Dasher: Heavy-Duty Stainless Steel with low friction scraper blades.

Controls: Automatic consistency controls for improved consistency.

Solid State Automatic Visual Mix Out System

Warranty:

Parts	1 year
Compressor	5 years
Evaporator	5 years

Options:

- Tune Up Kit
- Parts Tray
- Syrup Rail
- Water Cooled - 3/4" Garden Hose Fitting
- Wash Out Kit - 3/8" Flare Fitting

We reserve the right to change specifications and product design without notice. Such revisions do not entitle the buyer to corresponding changes, improvements, additions or replacements for previously purchased equipment.



WWW.ZAMA-ENETRPRISE.COM
1-866-425-5669 Fax: 1-305-670-0044
Miami, FL 33156



Made in the USA